

# ***SENSALERT PLUS***<sup>®</sup>

HART Communications Board

(Highway Addressable Remote Transducer)

User Manual

Document No. 360-0095-01

(Revision D)

***SENSIDYNE***<sup>®</sup>

Sensidyne, LP. • 16333 Bay Vista Drive  
Clearwater, Florida 33760 USA

800-451-9444 • +1 727-530-3602 • +1 727-539-0550 [fax]  
web: [www.sensidyne.com](http://www.sensidyne.com) • e-mail: [info@sensidyne.com](mailto:info@sensidyne.com)

## • Field Installation Kit

If you have ordered the field install kit p/n 821-0220-02, you will need to install the HART Card into your SensAlert Plus transmitter as follows (If not skip to **Set Up**):

1. Disconnect Power.
2. Open or Unscrew cover – (Note: On the “HD and XP” Option when doing more than one transmitter, keep cover and transmitter Body as a matched set).

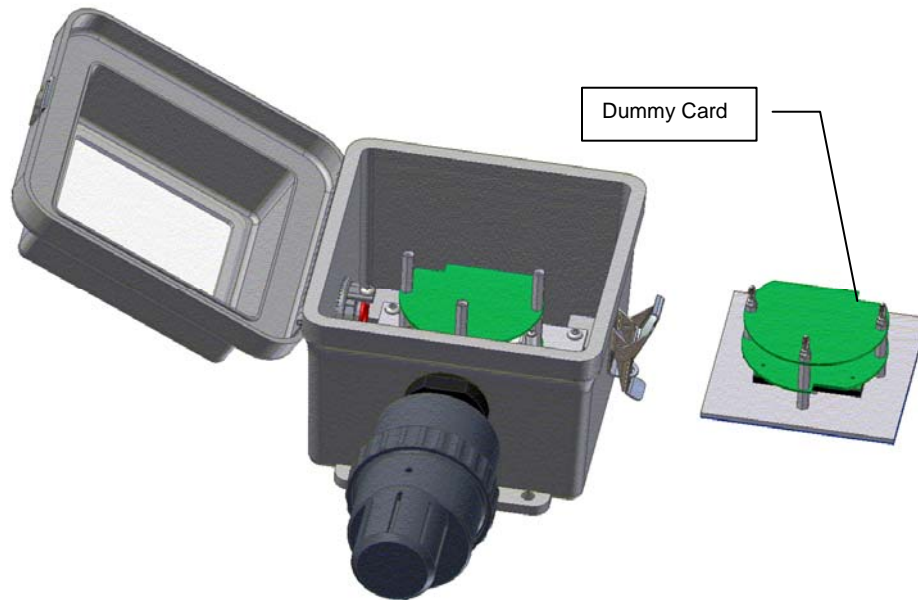

“GP”

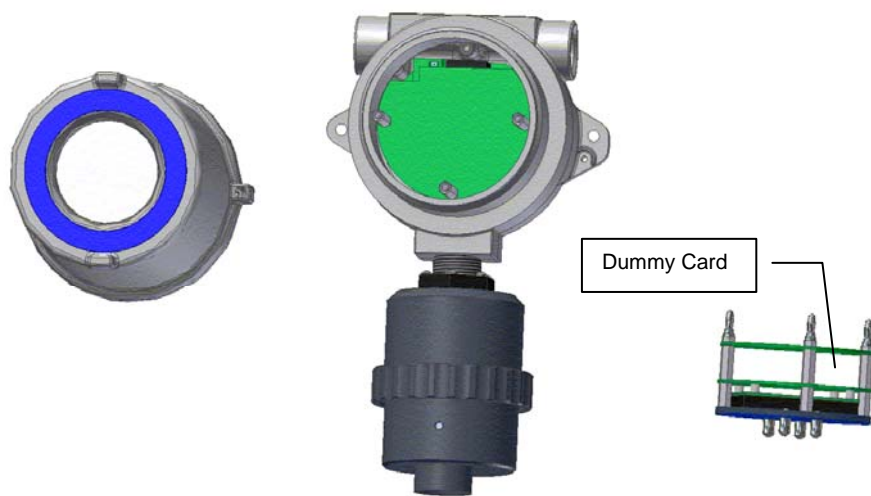

“HD and XP”

3. Gently unplug the Display Assembly and place it face down on a clean static free work surface.

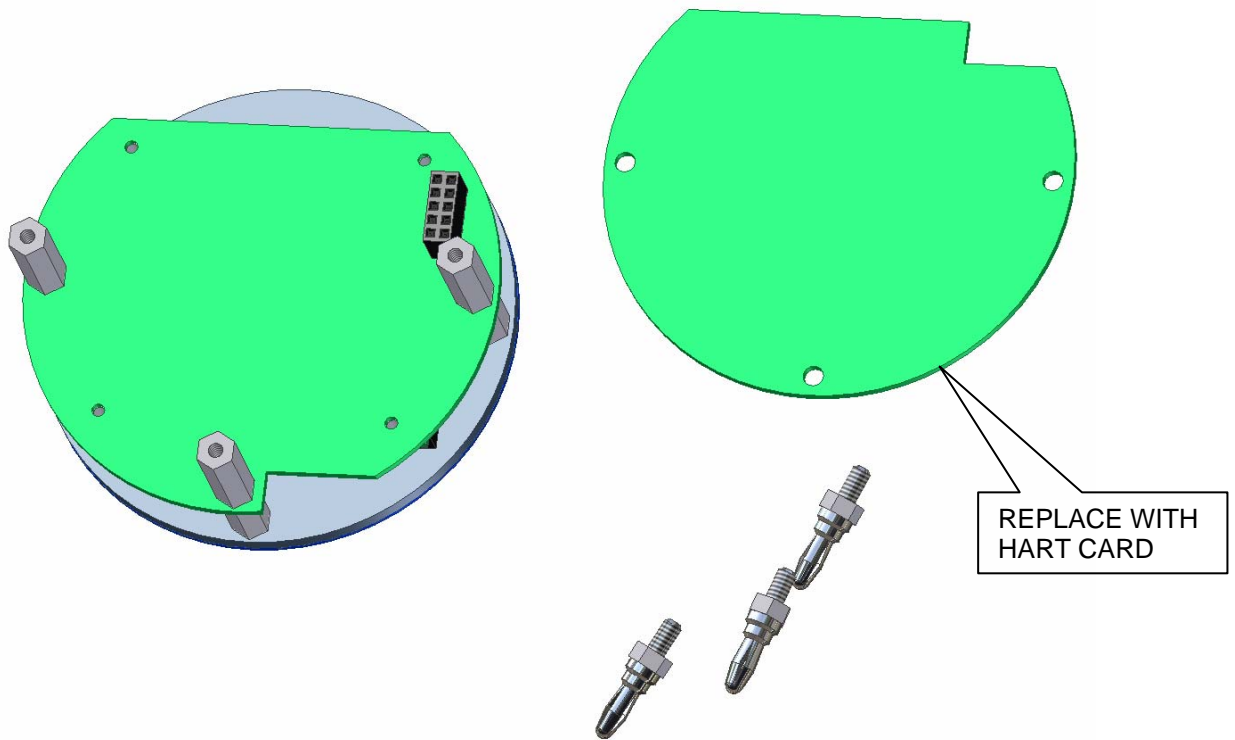

HD and XP SHOWN

4. Unscrew the Banana Plugs and remove the "dummy Card". Retain all hardware.
5. Place the HART Card on the Hex Stand-offs and gently couple the Electrical Plug into the jack on the Display Printed Circuit Board Assembly.
6. Install the Banana Plugs into the Hex Stand-offs. Use two 1/4" wrenches to tighten. Set Upper Display Assembly aside
7. Remove the Banana Jacks from the remaining assembly and remove the Relay Board to access the Power Plug on the Power Supply Board.

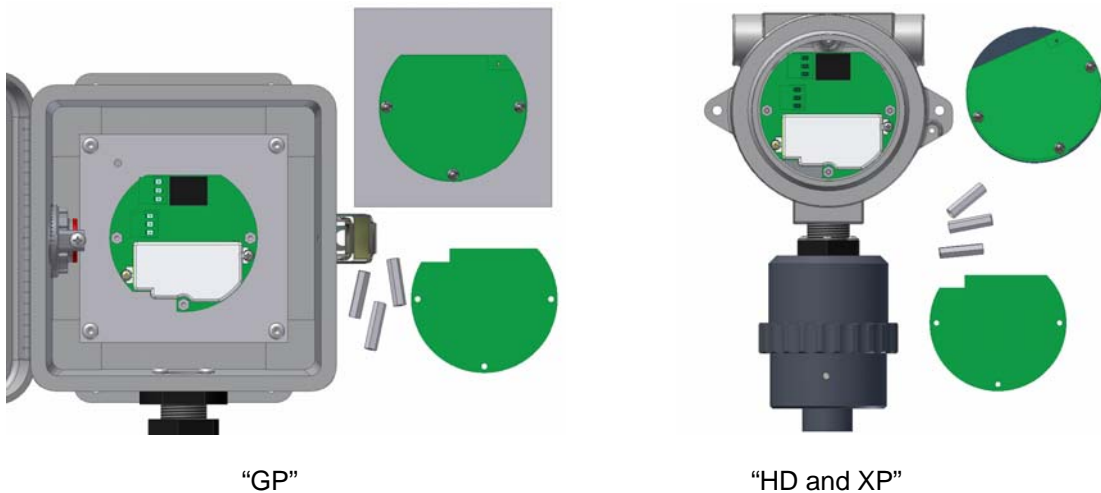

8. Add the Black Wire and the White Wire from the Hart Card to the Black and the White Wires in the Power Plug on the Power Supply Printed Circuit Board as shown.

# SensAlert Plus HART Communications Board

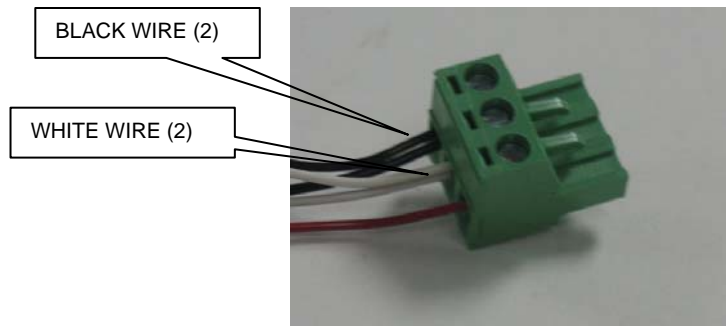

9. Reinstall the Relay Board and secure with the Banana Jacks. For "GP" use two 1/4" wrenches to tighten

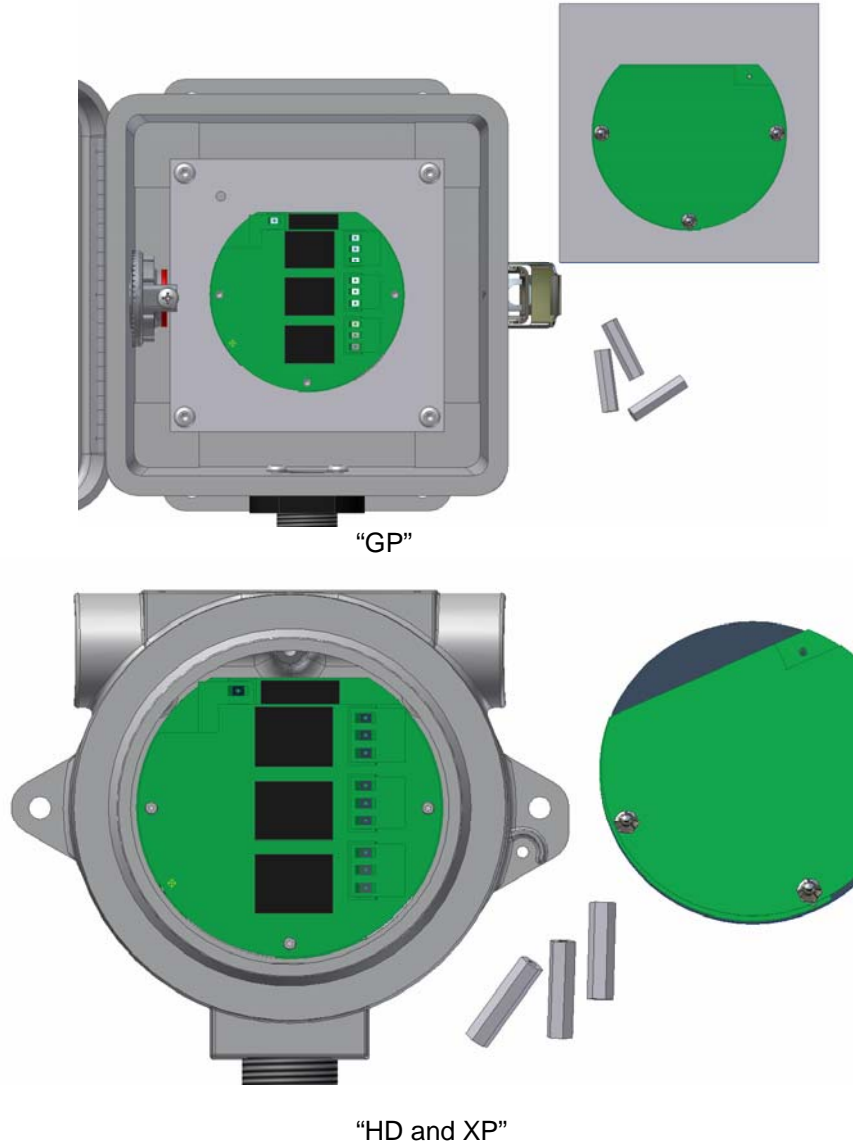

10. Proceed with **"SET UP"**.

- Set Up

NOTE

**The HART Communications Board is installed at the factory and prewired to the Three wire Non IS Power Supply Board (see Figure). Make certain you preserve the prewired connections when you wire the power supply during transmitter installation (Refer to Section 2.5 of the Transmitter User Manual [PN° 360-0087-02]).**

HART communications wiring should connect to the labeled terminals of TP1 on the Three wire Non IS power supply board in the base of the transmitter.

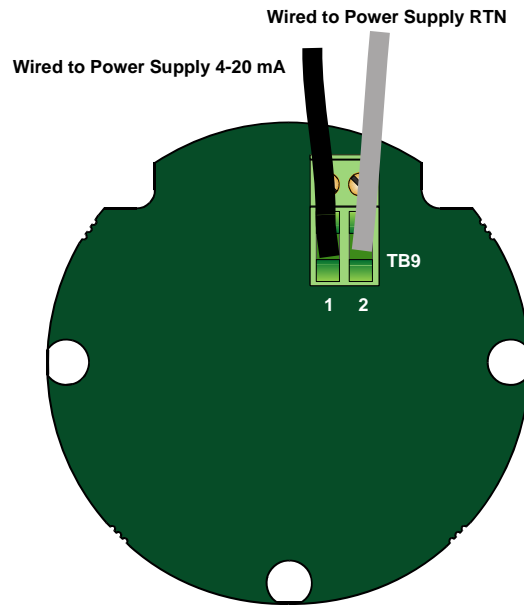

- Refer to SensAlert Plus User Manual  
(P/N: 360-0087-02)

The following section is reprinted from the SensAlert Plus User Manual. A properly installed HART Communication Board will indicate Hart Comm at step 5.2.5.5. If “Modbus Comm.” Or “No Comm Installed” appears, an improper Board has been installed in the transmitter.

## 5.2 Main Menu

As shown on the example display to the right, the top level (main) menu allows the selection of several submenus, documented below. Selecting OK brings up the submenus.

### 5.2.5 System Configuration

The System Configuration menu provides a large number of functions for configuring the operation of the unit. These include conducting a self test, alarm and relay setup, adjusting the 4 mA & 20 mA outputs, setting the date and time, communications setup, adjusting TOD cell functions, setting combustible sensor parameters, and setting a password.

#### 5.2.5.5 Communication Setup

This menu provides adjustment for both standard and optional installed communications methods. Options installed will be displayed.

Possible options are

Hart Comm  
Modbus Comm

(If no Communications Option is installed Display will read)

No Comm Installed

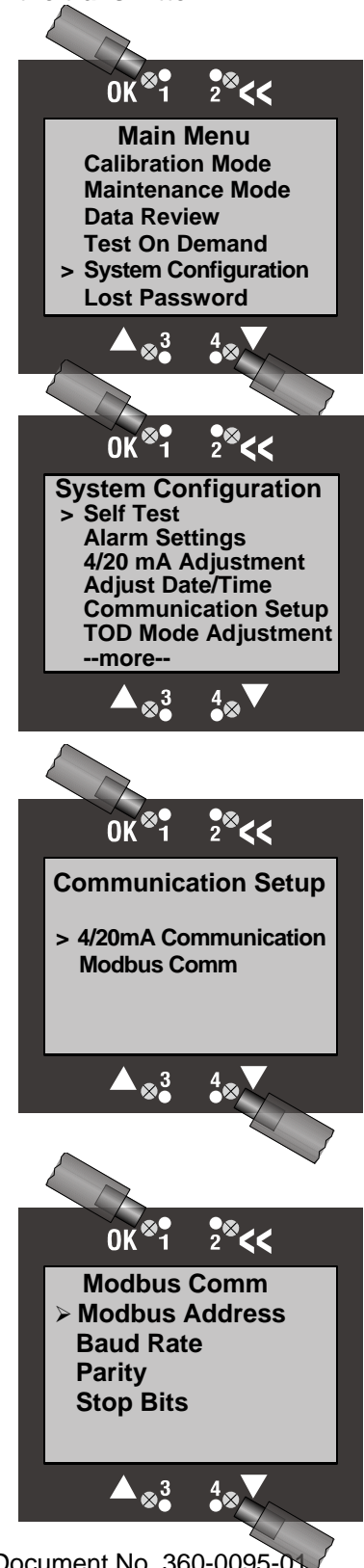

### 5.2.3 Data Review

Data review allows the examination of data stored by the unit. Data reviews are available for the Test-On-Demand gas generating cell, the installed sensor, Fault Currents, Active Alarms/Faults, Rly Alm Fault Config., Calibration Info, and Communication Review.

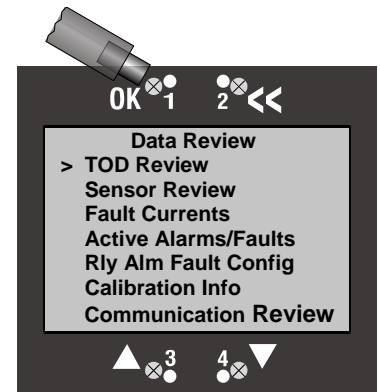

#### 5.2.3.7 Communication Review

The Communication Review screen displays the present setting Of the 4/20mA Current Loop (SensAlert sensor ID or None). Depending on which Communications Option is installed (None, HART, or Modbus) the display will vary.

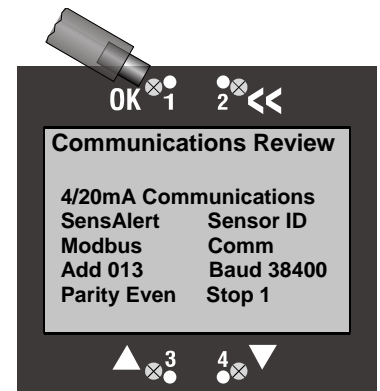

## 5.1 Menu Map

### 5.5. Communication Setup

#### 5.5.1. 4-20ma Communications

- 5.5.1.1. None
- 5.5.1.2. SensAlert Sensor ID

#### 5.5.2. Hart Comm or Modbus or No Comm Installed

- 5.5.2.1. Hart Comm
  - 5.5.2.1.1. – No User Adjustments Through this Interface Use Current Loop
- 5.5.2.2. Modbus Comm
  - 5.5.2.2.1. Modbus Address
  - 5.5.2.2.2. Baud Rate
  - 5.5.2.2.3. Parity
  - 5.5.2.2.4. Stop bits
- 5.5.2.3. No Comm Installed
  - 5.5.2.3.1. -No Communications Board Installed

- Implemented HART Commands

This section provides information about the implementation of the HART Protocol on the Sensidyne SensAlert Plus Transmitter.

The basis of Sensidyne's implementation of the HART protocol is HART Revision 5 with one device specific command to allow updating of certain dynamic variables. This command will allow the HART host software to change alarm levels, enable/disable alarms, etc.

The following HART Commands have been implemented in the SensAlert Plus device. Hart commands are divided as follows: Universal Commands (UC), Common Practice Commands (CPC), and Device Specific Command (DSC).

## Universal Commands

Command	Label	Function / Description
0	Read unique identifier	Mfg ID = 81 Device Type = 239 Device ID = 001 (SensAlert boards are not serialized; all will report Device ID 001)
1	Read primary variable	Primary Variable is Gas Concentration. [Dynamic variable #1 ]. Appropriate units will be reported.
2	Read current & % of range	Loop current is reported in mA.[Dynamic variable #0 ]. Percent of range is reported in %.
3	Read current and four (predefined) dynamic variables	Loop current is reported in mA. [Dynamic variable #0 ] Primary Variable is Gas Concentration. [Dynamic variable #1 ] Secondary Variable is TWA Gas Concentration. [Dynamic variable #2 ] Third Variable is Sensor Temperature. [Dynamic variable #3 ] Fourth Variable is Sensor Type.[Dynamic variable #4 ]
12	Read message	The 32 character message is read from internal non-volatile memory and reported to the HART host.
13	Read tag, descriptor, date	The 8 character TAG, 16 character DESCRIPTOR and the DATE are read from internal non-volatile memory and reported to the HART host.
17	Write message	The 32 character message provided by the HART host is written to internal non-volatile memory.
18	Write tag, descriptor, date	The 8 character TAG, 16 character DESCRIPTOR and the DATE provided by the HART host are written to internal non-volatile memory.

## Common Practice Commands

**Command 33 – Read Dynamic Variable.** Up to four dynamic variables can be requested by the HART host and their current values will be reported with appropriate units to the host. The following table lists the dynamic variables.

Var #	Description	Units
0	Loop Current	mA
1	Primary Variable (PV) - Gas Concentration	Gas Units
2	TWA Gas Concentration	Gas Units
3	Sensor Temperature	Deg Celsius
4	Sensor Type - 16-bit value (Converted to 32-bit float for HART)	No Units
5	Maximum / Full Scale Value	Gas Units
6	Minimum Span	Gas Units
7	Maximum Span	Gas Units
8	Alarm 1 Setpoint	Gas Units
9	Alarm 2 Setpoint	Gas Units
10	Alarm 3 Setpoint	Gas Units
11	TWA Alarm Setpoint	Gas Units
12	Cal Pre Exposure	Gas Units
13	Cal Gas Concentration	Gas Units
14	Date of Last Calibration - Year	No Units
15	Date of Last Calibration – Month	No Units
16	Date of Last Calibration – Day	Days
17	Time of Last Calibration - Hour	Hours
18	Time of Last Calibration - Minute	Minutes
19	Time of Last Calibration - Second	Seconds
20	TOD Peak Value	Gas Units
21	Date of Last TOD - Year	No Units
22	Date of Last TOD - Month	No Units
23	Date of Last TOD - Day	Days
24	Time of Last TOD - Hour	Hours
25	Time of Last TOD – Minute	Minutes
26	Time of Last TOD - Second	Seconds
27	Display S/W Version	No Units
28	Comm S/W Version	No Units
29	Head Unit S/W Version	No Units

Table Continued on next page

Var #	Description	Units
30	Sensor S/W Version	No Units
31	Maximum Gas Concentration	Gas Units
32	Date of Maximum Gas Concentration - Year	No Units
33	Date of Maximum Gas Concentration - Month	No Units
34	Date of Maximum Gas Concentration - Day	Days
35	Date of Maximum Gas Concentration - Hour	Hours
36	Date of Maximum Gas Concentration - Minute	Minutes
37	Date of Maximum Gas Concentration - Second	Seconds
38	Minimum Sensor Temperature	Deg Celsius
39	Date of Minimum Temperature - Year	No Units
40	Date of Minimum Temperature - Month	No Units
41	Date of Minimum Temperature - Day	Days
42	Date of Minimum Temperature - Hour	Hours
43	Date of Minimum Temperature - Minute	Minutes
44	Date of Minimum Temperature - Second	Seconds
45	Maximum Sensor Temperature	Deg Celsius
46	Date of Maximum Temperature - Year	No Units
47	Date of Maximum Temperature - Month	No Units
48	Date of Maximum Temperature - Day	Days
49	Date of Maximum Temperature - Hour	Hours
50	Date of Maximum Temperature - Minute	Minutes
51	Date of Maximum Temperature - Second	Seconds

**Note:** When a gas sensor is plugged into the head, the appropriate “units” for that type of gas is reported to the HART communications board. The correct units for the selected gas will be used for any of the variables that have “Gas Units” in the units column.

**Command 48 – Read Additional Device Status.** At the HART host's request, 48 status bits (i.e., 6 status bytes) are reported to the hosts. The table below lists the definitions of the 48 status bits reported by Command 48.

Byte 0	Bit 0	TOD Failed
	Bit 1	Not Used
	Bit 2	Not Used
	Bit 3	Not Used
	Bit 4	Not Used
	Bit 5	Not Used
	Bit 6	Not Used
	Bit 7	Not Used
Byte 1	Bit 0	Zero Started
	Bit 1	Zero Good
	Bit 2	Zero Failed
	Bit 3	Calibration Started
	Bit 4	Calibration Good
	Bit 5	Calibration Failed
	Bit 6	TOD Started
	Bit 7	TOD Good
Byte 2	Bit 0	Relay 1 Latching
	Bit 1	Relay 2 Latching
	Bit 2	Relay 3 Latching
	Bit 3	Relay 4 Latching
	Bit 4	Not Used
	Bit 5	Not Used
	Bit 6	TOD Test Fail Active
	Bit 7	TOD Fail Enable
Byte 3	Bit 0	Alarm 1 Active
	Bit 1	Alarm 2 Active
	Bit 2	Alarm 3 Active
	Bit 3	Alarm 4 Active
	Bit 4	Alarm 1 Enabled
	Bit 5	Alarm 2 Enabled
	Bit 6	Alarm 3 Enabled
	Bit 7	Alarm 4 Enabled
Byte 4	Bit 0	Head Fail Enable
	Bit 1	Sensor Missing Enable
	Bit 2	Sensor Fail Enable
	Bit 3	Sensor End of Life Enable
	Bit 4	TOD End of Life Enable
	Bit 5	Loop Current Out of Tolerance Fault Enable
	Bit 6	Calibration Mode Active Fault Enable
	Bit 7	Maintenance Mode Active Fault Enable
Byte 5	Bit 0	Head Fail
	Bit 1	Sensor Missing
	Bit 2	Sensor Fail
	Bit 3	Sensor End of Life
	Bit 4	TOD End of Life
	Bit 5	Loop Current Out Of Tolerance
	Bit 6	Calibration Mode Active
	Bit 7	Maintenance Mode Active

## Device Specific Command

**Device Specific Command 79 – Write Dynamic Variable.** This command is “borrowed” from HART Revision 6 and is formatted in the same way.

A single HART variable number along with a floating point value is provided by the HART host. The action performed by the SensAlert Plus device in response to this command is outlined below.

The following 4 variables can be directly updated by the HART host:

Dynamic Variable 8 = Alarm 1 Setpoint  
 Dynamic Variable 9 = Alarm 2 Setpoint  
 Dynamic Variable 10 = Alarm 3 Setpoint  
 Dynamic Variable 11 = TWA Alarm Setpoint

Various bit functions can be changed through special use of this command. Bit functions have “coil numbers” assigned to them.

To “turn on” a bit function, Dynamic Variable 40 is loaded with the “coil number” related to the selected bit function.

To “turn off” a bit function, Dynamic Variable 41 is loaded with the “coil number” related to the selected bit function.

Any requests to update variables other than 8, 9, 10, 11, 40 or 41 will be ignored.

The table below lists the “Coil Numbers” writable by the HART host along with their designated functions.

Coil 0	On -> Start Zeroing Sensor
Coil 3	On -> Start Sensor Calibration
Coil 6	On -> Start “TOD”
Coil 9	On -> Stop Sensor Calibration
Coil 16	On -> Clear Latched Relays
Coil 20	Enable/Disable Alarm 1
Coil 21	Enable/Disable Alarm 2
Coil 22	Enable/Disable Alarm 3
Coil 23	Enable/Disable Alarm 4
Coil 24	Enable/Disable Relay 1 Latching
Coil 25	Enable/Disable Relay 2 Latching
Coil 26	Enable/Disable Relay 3 Latching
Coil 27	Enable/Disable Relay 4 Latching
Coil 31	Enable/Disable TOD Fail
Coil 40	Enable/Disable Head Fail
Coil 41	Enable/Disable Sensor Missing
Coil 42	Enable/Disable Sensor Fail
Coil 43	Enable/Disable Sensor End Of Life
Coil 44	Enable/Disable TOD End of Life
Coil 45	Enable/Disable Loop Calibration Out Of Tolerance
Coil 46	Enable/Disable Calibration Mode Active Fault
Coil 47	Enable/Disable Maintenance Mode Active Fault

**For further information about the HART protocol contact  
the HART Communication Foundation at [www.hartcomm.org](http://www.hartcomm.org)**

**HART Communication Foundation  
9390 Research Blvd., Suite I-350  
Austin TX 78759  
Tel: 512-794-0369  
Fax: 512-794-3904**

# ***SENSIDYNE***<sup>®</sup>

Sensidyne, LP. • 16333 Bay Vista Drive  
Clearwater, Florida 33760 USA  
800-451-9444 • +1 727-530-3602 • +1 727-539-0550 [fax]  
web: [www.sensidyne.com](http://www.sensidyne.com) • e-mail: [info@sensidyne.com](mailto:info@sensidyne.com)



ISO 9001:2000 Registered